

Glass Beads

BEAD' SIZES:

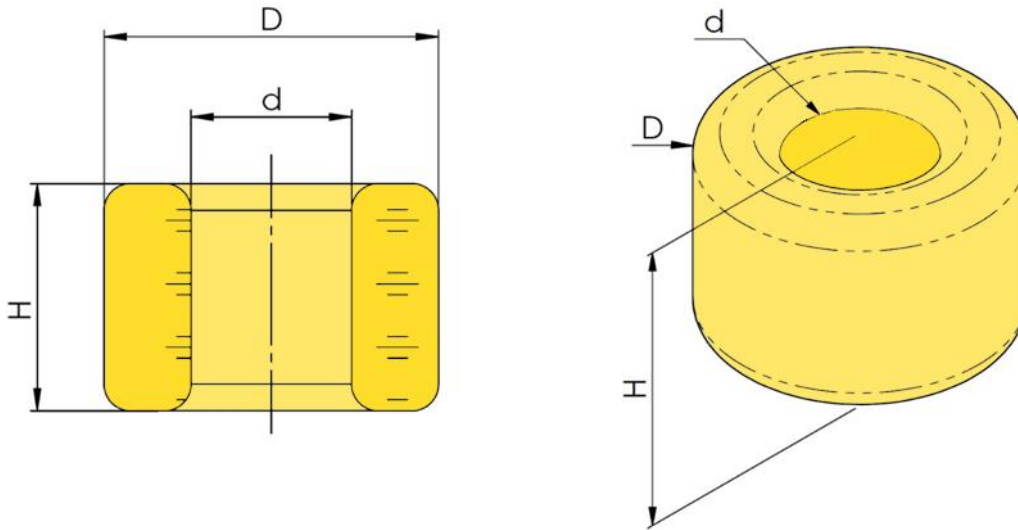

AVAILABLE SIZES FOR THE ORDER:

Bead's outer diameter (D) mm:	Diameter SIZE CODE:	Bead's height (H) mm:	Height SIZE CODE:	Bead's hole diameter (d) mm:
1.9-2.0	13/0	1.5 +/- 0.075	5	1.2 +/- 0.05
2.0-2.1	13/0-II	1.6 +/- 0.075	6	
2.3-2.6	10/0	1.6 +/- 0.075	6	
		1.7 +/- 0.075	7	
2.7-2.8	10/0-II	1.8B +/- 0.075 (≤ 1.85)	8B	
		1.8 (> 1.85)	8	

BEAD'S SIZE ORDER CODE:

- Specify the **outer diameter size** of the required bead. For example: you need beads with outer diameter size **2.5 mm** then you must write size code **10/0**
- Specify the **height** of the bead. For example: you need beads with outer diameter 2.7 mm and height **1.6 mm** then you must write 10/0-II-6
- NOTICE:** most common height for the beads available is **8B** (1.8B mm)

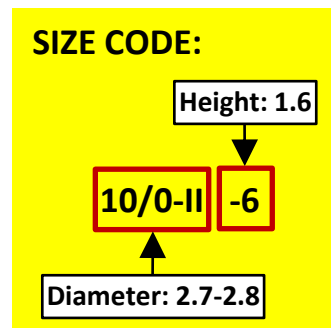

ITEMS TO NOTICE WHEN USING THE BEADS:

- CAUTION!** Do not wash the beads with acids.
- CAUTION!** Colour of the beads may fade if wash them in $\geq 200^{\circ}\text{C}$ water with chemicals.
- CAUTION!** Plating of the beads may come off after friction.
- CAUTION!** Colour of the beads may be changed by oxidation over time.